

## PRODUCTS DETAILS

Dimensions	592x52x596 (LxIxh en mm)
Weight	7.5 Kg
Material	Inox 304L
Color	Mirror polished stainless steel Brushed stainless steel

## SPECIFICATIONS

Installation	Countertop mixer
Spout	Fixed
Spout reach	299 mm
Recommended water pressure (bar)	2.5 - 3

Flow rate (l/min)	6
Cartridge	Progressive
Join	G 3/8"
Number of tap holes	1

## KIT CONTENT

Supplied parts	<ul style="list-style-type: none"> <li>Complete mixer tap</li> <li>G 3/8" connection hoses</li> <li>Tool for removing the aerator</li> </ul>
----------------	--

## WARRANTY

Warranty	2 years
----------	---------

## MAINTENANCE

<b>Tap body</b> Regular cleaning	<ul style="list-style-type: none"> <li>Mild solution (10-15% white vinegar + water)</li> <li>Let it sit 3-4 min</li> <li>Rinse with clear water</li> <li>Dry with a soft cloth</li> </ul>
<b>Aerator</b> Cleaning at least once a year	<ul style="list-style-type: none"> <li>Soak in a mild solution (15-20% white vinegar + water)</li> <li>Rinse with clear water</li> </ul>
<b>Avoid</b>	<ul style="list-style-type: none"> <li>Harsh cleaning agents</li> <li>Abrasive sponges</li> </ul>

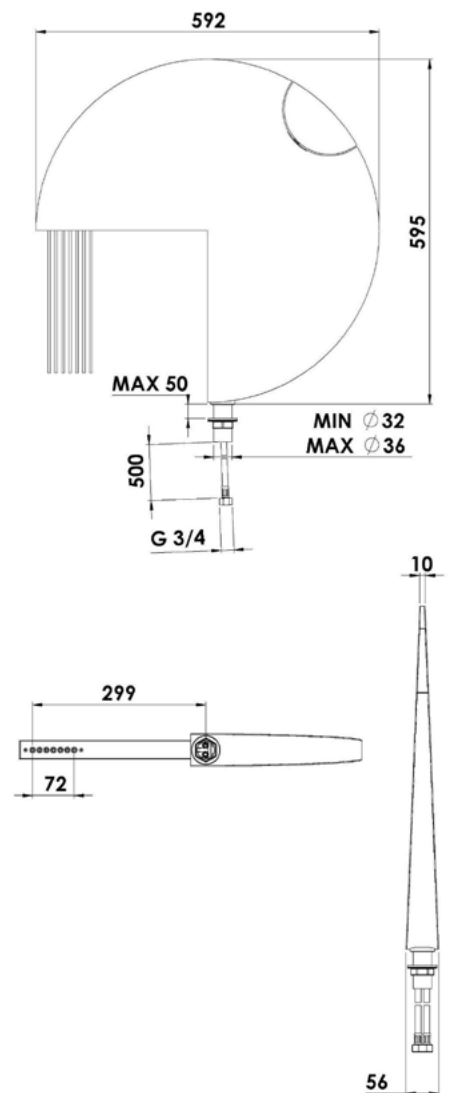
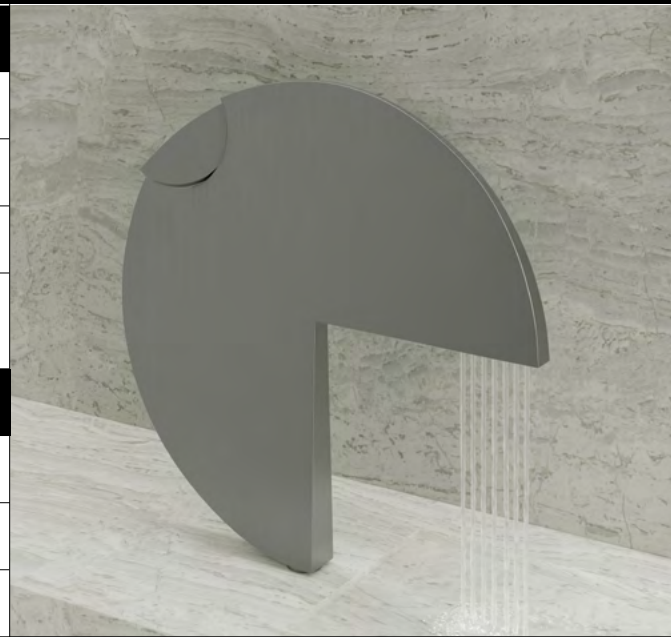

\*Our plans indicate all the necessary dimensions, taking into account standard tolerances. These dimensions are indicative. The exact dimensions can only be taken on the finished product.